

Data sheet

Analogue level measurement with coated tube

Type: ANM-20...

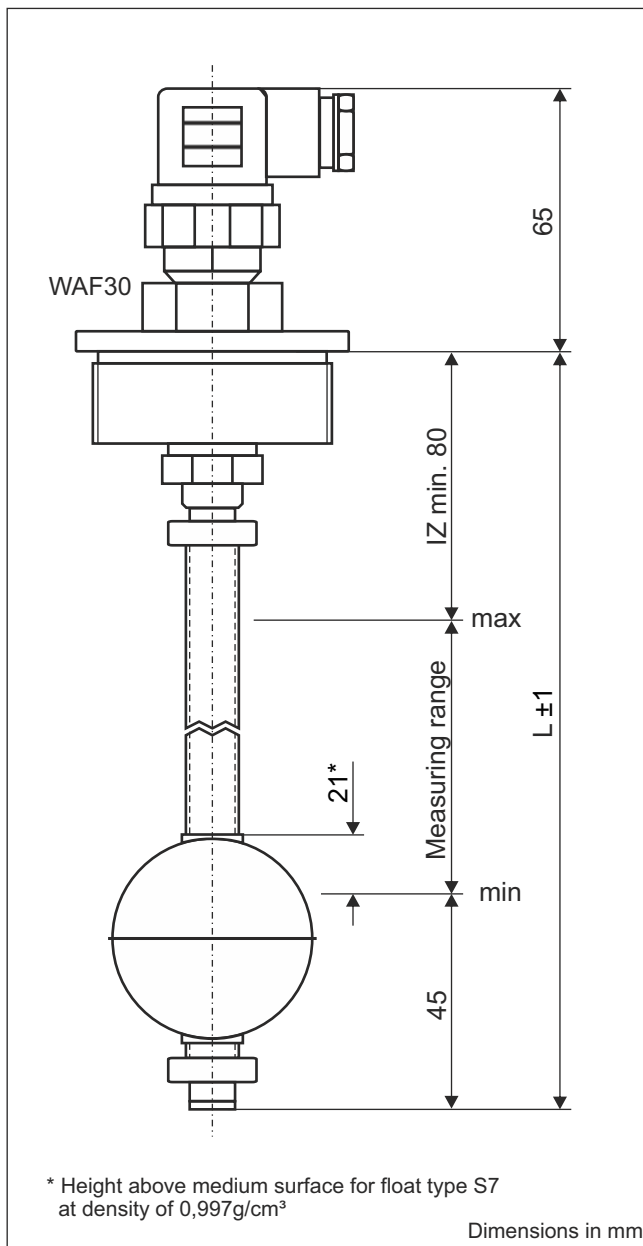

Terminal diagram

Passive -
without measuring
transducer,
potentiometer function
ANM-20

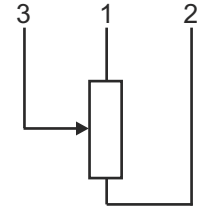

Order key

Example: ANM-20. 80. 200 . 2,5

Type

Inactive zone (IZ) e.g. 80mm

Length L of tube

Resolution

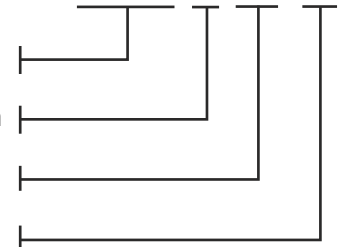

Subject to change

Technical data

Connection:	plug-type connector 3-pole + PE DIN EN 175301-803 (DIN 43650), material PA
Mounting:	thread 2", material PP
Seal:	O-ring, material EPDM
Tube:	ø12mm, length L ± 1mm, max. 1m further lengths on demand material stainless steel 1.4571 coated with PTFE-sleeve
Float:	ø52mm, material stainless steel 1.4571, type S7
Resolution:	2,54mm / 5,08mm reed chain on customer specification
Output:	potentiometer function
Inactive zone:	IZ accord. to customer specification, min. 80mm
Measuring range:	measuring range = length - IZ - 45mm
Pressure:	atmospheric
Operating temperature:	-20°C to 80°C in medium, -20°C to 70°C above mounting
Protection rating:	IP 65